

# DOC 202

For tractors 50-70 hp (4,3 m / 5,0 m)



Hydraulic hedge mower with side shift and 90° rotating column with shock resistant hydraulic safety device for tractors HP 50/70 and weight 2400/2800 kg, suitable for working on local and trunk roads and farms.

<b>DOC 202</b>	<b>4.3</b>	<b>5.0</b>
A mm	4.300	5.000
B mm	4.500	5.200
C mm	3.400	4.200
D mm	2.500	3.300
E mm	3.300	4.100
F mm	550	550

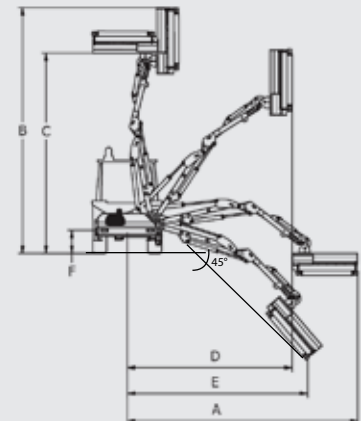

## Rotor with shackle (exchangeable tools)

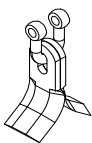

**KC1**  
Ø max 3 cm  
**STANDARD EQUIPMENT**

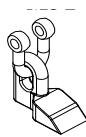

**HC1**  
Ø max 4 cm



**HF2**  
Ø max 5 cm



Tools n. 16 kits per rotor

Arm mower	DOC 202 4.3	DOC 202 5.0
<b>Extension</b> E mm	4.300	5.000
<b>Weight</b> kg	730	760
<b>Oil tank</b> L	100	100
<b>Head</b> model	20.2	20.2
<b>Pump</b> l/min	60+15	60+15
<b>Hydraulic Motor</b> HP [kW]	35 (26)	35 (26)

### Tractor

<b>Power</b> HP [kW]	50/70 (37/52)	50/70 (37/52)
<b>3-point linkage</b> Cat.	Cat. 1-2	Cat. 1-2
<b>Weight</b> kg	2.400	2.800
<b>Width</b> m	1,80	2
<b>PTO</b> rpm	540	540

### Technical features and standard equipment

- Frame - 1<sup>st</sup> arm - 2<sup>nd</sup> arm in structural steel ST 52
- 90° rotating column and shock resistant hydraulic safety device
- Three points hitch 2<sup>nd</sup> category
- Oil tank 100 l
- Double gear pump group 3+2 - 60+15 l/min
- Bidirectional hydraulic motor HP 35 power
- Distributor with remote controls with mm 3000 flexible cables
- Self-levelling floating system
- Feeler roller recordable on 3 positions
- Head rotating angle 200°
- Helicoidal rotor with jointed cut blade KC1
- Rotor turning at 3000 rpm
- Fixing tie-rods - Cardan joint
- Rear underrun protection with lights
- Flail head mm 1050 MODEL 20.2 TTD 105 with direct transmission

### Accessories on request

- Heat exchanger
- Electric distributor with joystick
- Electric command of the rotor
- Proportional power-assisted with joystick
- Tie rods adapter Cat. 2

### Terminal tools

In replacement of the standard mulcher

p.76



**MODEL**  
T3 90  
T3 70

p.82



**HEDGE CUTTING BAR**  
BF15

p.83



**PRUNING SHEAR BAR**  
BTZ5 15  
BTZ5 18  
BTZ10 16

p.84



**FOREST CUTTING DISC BAR**  
BD2

p.85



**DITCH CLEANER**  
PF40